

Surface Track

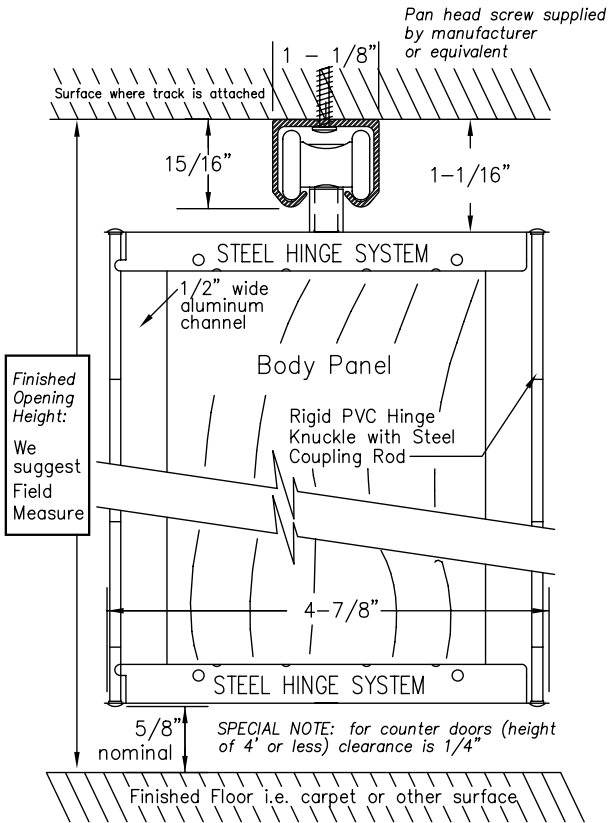

Recessed Track

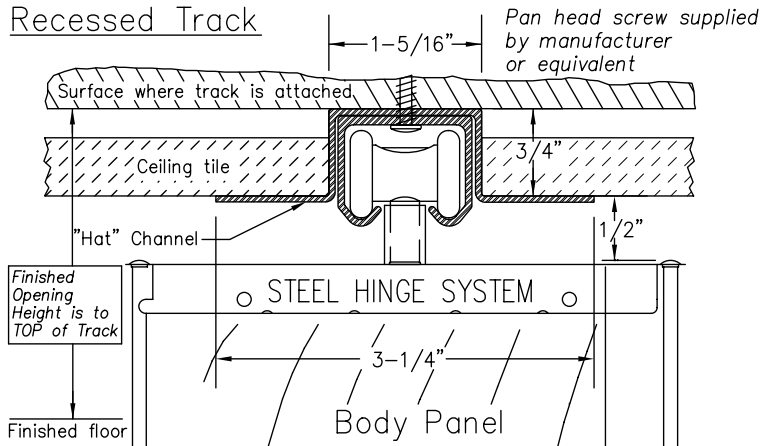

I-Beam Track

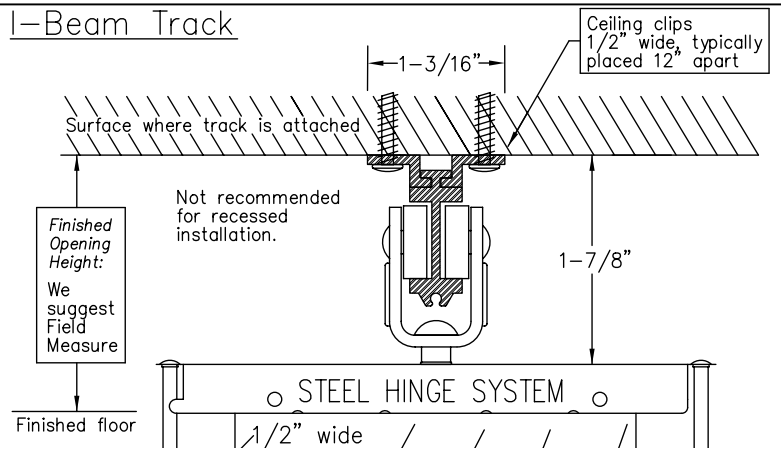

Door Types

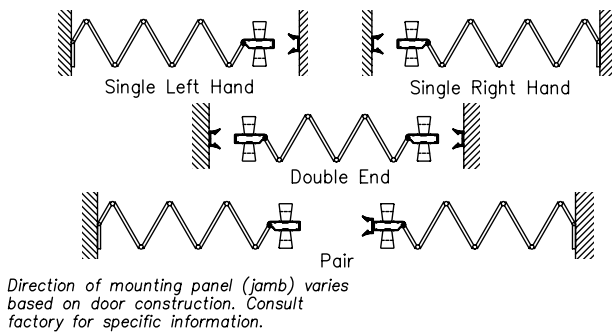

Lead Post, Jamb Moulding & Handle

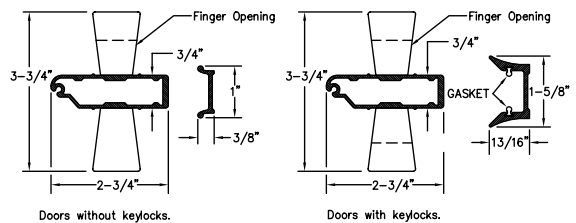

Sliding Jamb Option

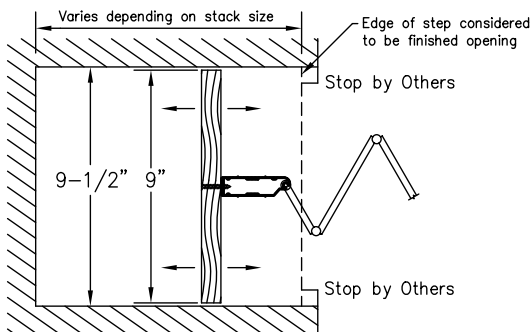

Mounting Panel

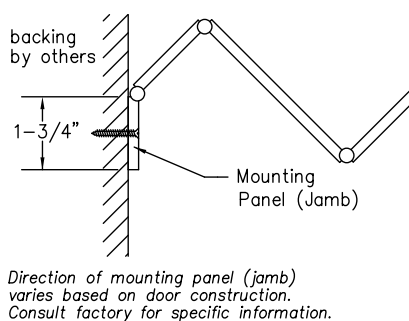

Multiple Meeting Option

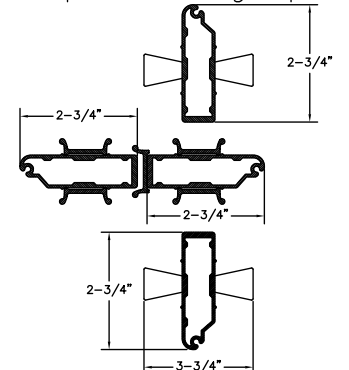

Stack Dimensions

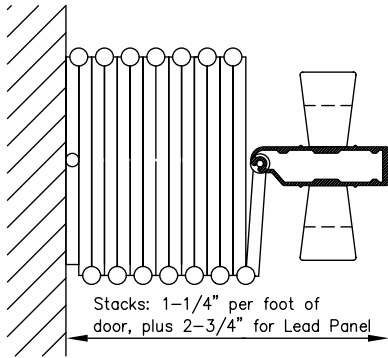

Intermediate Rolling Post

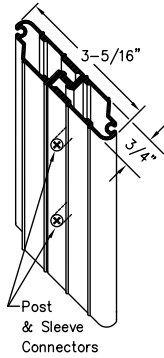

Privacy Latch



Keylock

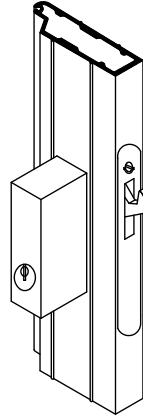

Single Cremone Bolt Keylock

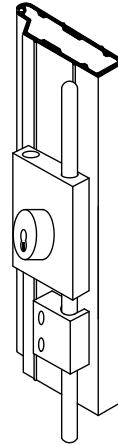

Double Cremone Bolt Keylock

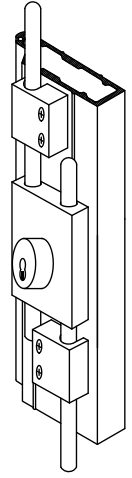

INFORMATION

Width	Custom made to any width
Height	Custom made to 10' -1"
Panels	Acrylic, natural hardwood or vinyl-lam
Side Channel	Aluminum: White, Brown, Sand or Clear
Panel Connector	Rigid Vinyl: White, Brown, Sand or Clear
	Coordinated with side channel
Hinge System	Steel: Dark Bronze or Clear
Wheels	Ball bearing nylon wheels on steel axles
Track	Aluminum (straight or curvable): Dark Bronze or Clear
Recessed Channel/ "Hat" Channel	Aluminum (straight only): White
Lead, Intermediate and Jamb	Aluminum: White, Brown, Sand or Clear Coordinated with side channel
Latch	Deadlatch with Key Lock two sides
Header	Construction Details by Others
Door Weight	<u>Height</u> <u>Average Weight</u> 6'-8" 10lbs. Per lineal foot 8'-1" 12lbs. Per lineal foot 10'-1" 15lbs. Per lineal foot 12'-1" 18lbs. Per lineal foot

See Woodfold Accordion Door brochure for additional details

Catch/Lock Options

Magnet	Magnet with strike plate
Privacy Latch	Deadlatch with thumb turn one side
Springlatch	Springlatch with thumb turn two sides
Keylock 1 Side	Deadlatch with thumb turn one side, keylock one side
Key and Single Bolt	Key and single bolt lock
Key and Double Bolt	Key and double bolt lock
Single Cremone	Single Cremone Bolt with Key Lock
Double Cremone	Double Cremone Bolt with Lock
Footbolts	Locking or non locking
Other Keyed Options	Keyed alike, custom keyed, construction core Contact manufacture for more details

Job Name: _____
 Job Location: _____
 Supplier: _____

Architects Acceptance

Qty.	Single/Pair	Single End/Double End	Left or Right Stack	Width X Height	Finish/Color	Comments

THESE SPECIFICATIONS ARE SUBJECT TO CHANGE WITHOUT NOTICE